

Inertia identification based on adaptive interconnected Observer of Permanent Magnet Synchronous Motor

Yudan Huang, Guohui Zeng

School of Electronic and Electrical Engineering Shanghai University of Engineering Science,
Shanghai, China

School of Electronic and Electrical Engineering Shanghai University of Engineering Science, Shanghai, China

Abstract: In order to achieve the inertia identification of permanent magnet synchronous motor, this paper presents an adaptive inter connected observer based on model reference adaptive and Rhomberg observer to observe the inertia of permanent magnet synchronous motor and build the simulation model in MATLAB. By the simulation analysis, the observer can identify the moment of inertia of permanent magnet synchronous motor accurately, at the same time has good robustness.

Key words: Inertia, MRAS, Rhomberg observer, PMSM, MATLAB

I. INTRODUCTION

With the development of modern industry, the AC servo system is more and more widely used in industrial production. Permanent magnet synchronous motor has good performance and is widely used in AC servo system. High performance AC servo system not only requires a quick response to the instruction, but also can have good stability when the servo system has a load. In the actual drive system, rotor inertia is an important mechanical parameters, when the load changes, inertia will be changed, which will bring greater influence to drive system's operating parameters. In order to make the drive system have good robustness and guarantee the high precision control, it is necessary to adjust the parameters of the controller of the drive system, which must be carried out to identify the inertia of the motor. In this paper, Based on model reference adaptive method and Rhomberg observer, an adaptive interconnected observer is established to identify the rotation inertia.

II. PERMANENTMAGNETSYNCHRONOUSMOTORMATHEMATICALMODEL

In this paper, the permanent magnet synchronous motor is SPMSM, that is: $L_d = L_q$, and use with maximum torque current ratio control strategy, that is: $i_d = 0$, so the mathematical model of permanent magnet synchronous motor can be turned into:

$$\begin{cases} u_d = -\omega_r L_q i_q \\ u_q = L_q \frac{di_q}{dt} + R_s i_q + e \\ T_e = \frac{3}{2} p \varphi_f i_q \\ T_e = J \frac{d\omega_r}{dt} + B \omega_r + T_L \end{cases} \quad (1)$$

Where u_d and u_q are the d- and q-axis voltage, respectively; i_d and i_q are the d- and q-axis stator current, respectively; ω_r is the rotor mechanical speed; L_d and L_q are the d- and q-axis inductance; R_s is the winding stator resistance; φ_f is the permanent-magnet flux linkage; e is the counter electromotive force; T_e is the electromagnetic torque; B is the viscous friction coefficient; T_L is the load torque; and p is the number of pole

pairs.

III. ADAPTIVE INTERCONNECTED OBSERVER

The establishment of the adaptive interconnected observer, which is based on model reference adaptive and Rhombberg observer and combination of the two together. In this paper, through the method of model reference adaptive to estimate the moment of inertia, and using Rhombberg observer for rotor speed estimation, then both estimated values are substituted into the two models, through the iterative process in order to get the precise value.

3.1 Model reference adaptive

The model reference adaptive method is a mature method in the field of parameter identification. It is based on the stability theory of Lyapunov and the ultra-stability theory of Popov, thus, it can guarantee the convergence of parameter identification. The main idea of the model reference adaptive is using the equation which contain the unknown parameter as an adjustable model and without unknown parameters as the reference model, and the two models' output have the same physical significance. The two models work simultaneously, and adjust the parameters of the adjustable model according to the output-error and appropriate adaptive rate, so as to achieve the target's output tracking reference model, and to achieve the purpose of that the output of control object can track the reference model. And the functional block figure is as follows fig.1.

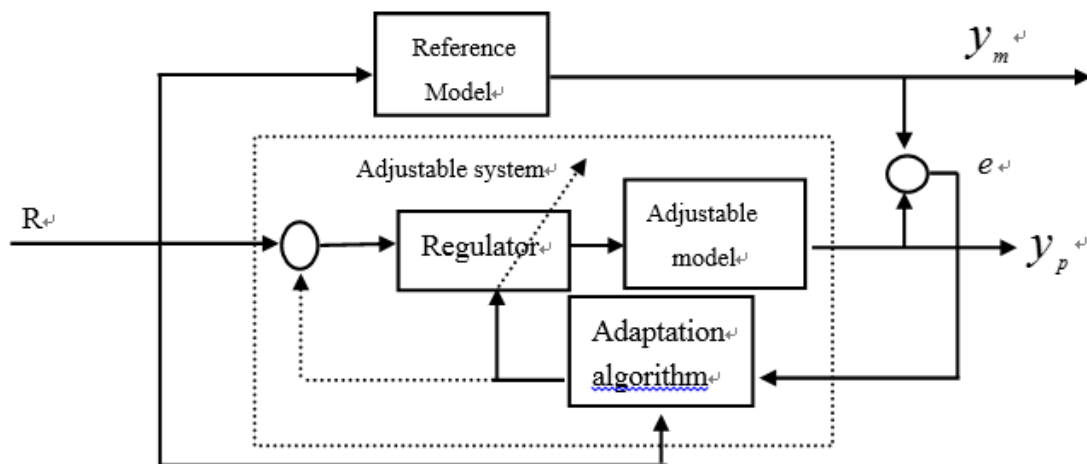

Fig.1 Model reference adaptive identification principle

In the AC servo system, the system dynamic equation as for:

$$T_e = T_L + B \frac{d\omega_r}{dt} + J \frac{d^2\theta_r}{dt^2} \quad (2)$$

The discretization of equation (2) as follows:

$$\omega_r(k) = \omega_r(k-1) + \frac{T}{J} [T_e(k-1) - T_L(k-1) - B\omega_r(k-1)] \quad (3)$$

Where T is the system sampling period.

In quick response AC servo system, the system sampling frequency is high, in a single cycle, the load torque can be considered as a constant. Meanwhile, AC servo system viscous friction coefficient is small, so it can be ignored. After the above analysis, the equation (3) can be simplified as:

$$\omega_r(k) = 2\omega_r(k-1) + b[T_e(k-1) - T_e(k-2)] \quad (4)$$

Where b is the identification parameter.

The equation (4) as the reference model, and then the adjustable model as follows:

$$\hat{\omega}_r = 2\omega_r(k-1) - \omega_r(k-2) + \hat{b}(k-1)[T_e(k-1) - T_e(k-2)] \quad (5)$$

Where $\hat{\omega}_r$ is the estimates value of speed signal; \hat{b} is the estimates value of identification parameter. According to the parallel model reference adaptive algorithm, we can refer to the inertia identification algorithm design model as follows:

$$\begin{cases} \Delta T_e = T_e(k-1) - T_e(k-2) \\ \hat{\omega}_r = 2\omega_r(k-1) - \omega_r(k-2) + \hat{b}(k-1)\Delta T_e(k-1) \\ \Delta \omega_r = \omega_r(k) - \omega_r(k-1) \\ \hat{b}(k) = \hat{b}(k-1) + \lambda \frac{\Delta T_e(k-1)\Delta \omega(k)}{1 + \lambda \Delta T_e(k-1)^2} \end{cases} \quad (6)$$

3.2 Rhomberg observer

The theory of state observer is proposed by Rhomberg, and its essence is a state estimator. It uses the input and output of the controlled object to estimate the state of the system, thus resolving the problem that the system can not be directly measured.

Through the motor dynamic equation (2) can get:

$$T_e = T_L + B \frac{d\omega_r}{dt} + J \frac{d^2\theta_r}{dt^2} \quad (7)$$

Ignoring the viscous coefficient and the motor without load, here is designed by the Rhomberg observer theory, and a closed-loop observer as follows:

$$\begin{cases} \begin{bmatrix} \dot{\hat{\theta}}_r \\ \hat{\theta}_r \\ \dot{\hat{\omega}}_r \\ \hat{\omega}_r \end{bmatrix} = \begin{pmatrix} 0 & 1 \\ 0 & 0 \end{pmatrix} \begin{pmatrix} \hat{\theta}_r \\ \hat{\omega}_r \end{pmatrix} + \begin{pmatrix} 0 \\ \frac{1}{J} \end{pmatrix} T_e + \begin{pmatrix} K_i \\ K_p \end{pmatrix} (\theta_r - \hat{\theta}_r) \\ \hat{y} = (1 \quad 0) \begin{pmatrix} \hat{\theta}_r \\ \hat{\omega}_r \end{pmatrix} \end{cases} \quad (8)$$

3.3 Interconnected observer design

From the above, the inertia of the motor is obtained by the model reference adaptive method, the rotor position and the speed of the motor can be obtained by the Rhomberg observer. In the process of inertia identification, rotor position and speed identification, they depend on each other. Identification of the inertia need the rotor position and speed of the rotor; Rotor position tracking and rotor speed identification, need to identify the inertia. Thus, the Interconnected observer can be get by equation (6) and (8):

$$\begin{cases} \Delta T_e = T_e(k-1) - T_e(k-2) \\ \hat{\omega}_r = 2\hat{\omega}_r(k-1) - \hat{\omega}_r(k-2) + b(k-1)\Delta T_e(k-1) \\ \Delta \hat{\omega}_r = \hat{\omega}_r(k) - \hat{\omega}_r(k-1) \\ \hat{b}(k) = \hat{b}(k-1) + \lambda \frac{\Delta T_e(k-1)\Delta \omega(k-1)}{1 + \lambda \Delta T_e(k-1)^2} \end{cases} \quad (9)$$

$$\begin{pmatrix} \dot{\hat{\theta}}_r \\ \hat{\theta}_r \\ \dot{\hat{\omega}}_r \\ \hat{\omega}_r \end{pmatrix} = \begin{pmatrix} 0 & 1 \\ 0 & 0 \end{pmatrix} \begin{pmatrix} \hat{\theta}_r \\ \hat{\omega}_r \end{pmatrix} + \begin{pmatrix} 0 \\ 1 \\ J \end{pmatrix} T_e + \begin{pmatrix} K_i \\ K_p \end{pmatrix} (\theta_r - \hat{\theta}_r)$$

$$\hat{y} = \begin{pmatrix} 0 & 1 \end{pmatrix} \begin{pmatrix} \hat{\theta}_r \\ \hat{\omega}_r \end{pmatrix}$$

The simulation block diagram in MATLAB is shown as follows:

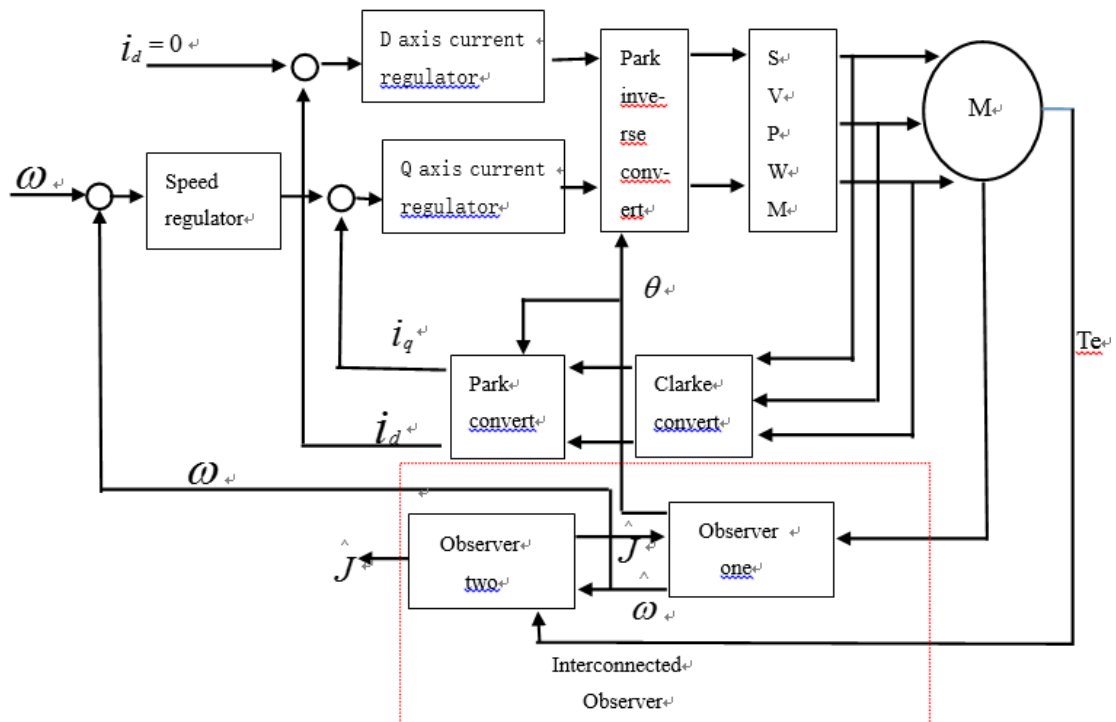

Fig.2 simulation block diagram

IV. MATLAB SIMULATION ANALYSIS

The basic parameters of permanent magnet synchronous motor are as follows:

$$R_s = 2.875\Omega ; \varphi_f = 0.175wb ; L_d = L_q = 8.5mh ; p = 2 ; J = 0.01kg \cdot m^2 .$$

The simulation waveforms in MATLAB are shown below:

Observation of the position and speed of the rotor:

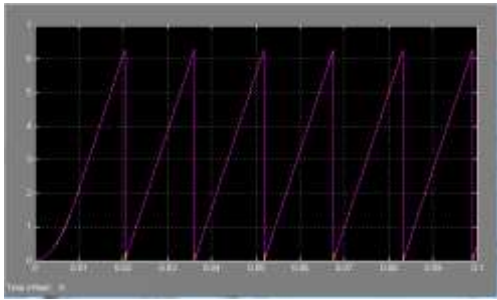

Fig.3 Rotor position tracking

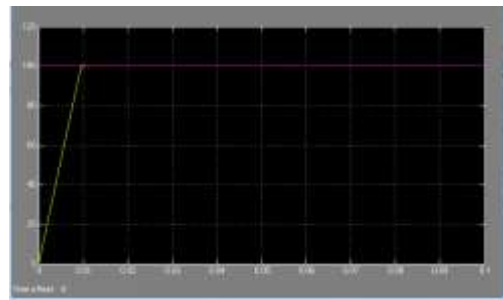

Fig.4 Rotor speed identification

Fig.3 is the rotor position tracking waveform and Fig.4 is the Rotor speed identification. In the figure of rotor position tracking, the horizontal axis represents time, the vertical axis represents curvature, seen from the waveform, the observer can accurately track the position of the rotor; in the figure of rotor speed identification, the horizontal axis represents time, the vertical axis represents angular velocity, similarly, there is a waveform diagram shows that the observer can accurate identification of the rotational speed.

Moment of inertia identification:

The inertia identification by the interconnected observer:

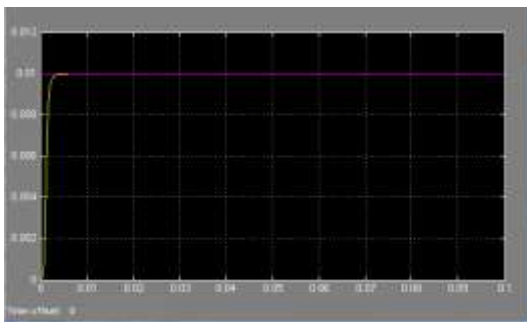

Fig.5 Constant speed

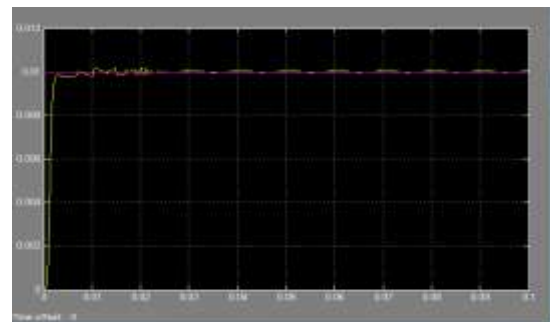

Fig.6 Speed sinusoidal

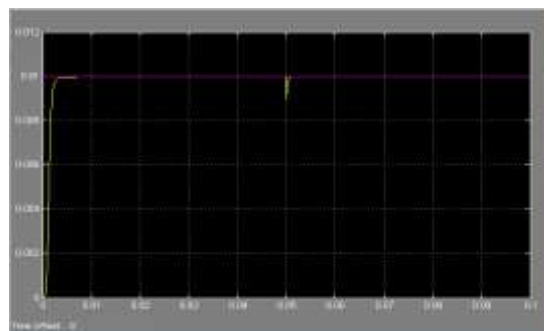

Fig.7 A step change in the load torque

Figures 5, 6, 7 are the inertia identification in different operating conditions of servo system, respectively. Fig. 5 identification of moments of inertia at constant speed; Fig. 6 identification of moments of inertia when a sinusoidal change occurs at a speed; Fig. 7 identification of moments of inertia when the load torque is changed. In Figure 5, the rotating speed is constant, the Internet observer in a very short period of time to achieve the accurate identification of inertia; In Figure 6, due to the sinusoidal changes in the speed, the overshoot of the

overshoot is generated during the process of identification, but the identification results still converge to the correct value after a period of time; In Figure 7, the load torque in 0.05 seconds time step changes occur. The identification results are similarly affected, but in a very short period of time, rapid convergence to the accurate values.

V. 5CONCLUSINO

This paper studies the model reference adaptive and Rhomberg observer. Combining Rhomberg observer and the model reference adaptive to establish the adaptive interconnected observer, and eventually realize the online identification of the inertia of the rotor. In the process of identification, the identification of moment of inertia is carried out by changing the different servo system operating conditions, By the simulation analysis, the adaptive interconnected observer can still identify the moment of inertia accurately when the servo system operating conditions is different.

VI. ACKNOWLEDGEMENTS

My deepest gratitude goes first and foremost to Professor ZENG Guohui, my supervisor, for his constant encouragement and guidance. He has walked me through all the stages of the writing of this thesis. Without his consistent and illuminating instruction, this thesis could not have reached its present form. Also I would like to express my heartfelt gratitude to my project team members, and they gave me help and time in listening to me and helping me work out my problems during the difficult course of the thesis.

At the same time, This work is supported by the Innovation foundation of SUES under Grant NO.E1-0903-15-01026.

REFERENCES

- [1] Huang Pan feng, Wang Dong ke, Meng Zhongjie, Liu Zheng xiong, Post-capture attitude control for a tethered space robot–target combination system, *Robotica*(2014)1–22.
- [2] M. Mengoni, L. Zarri, A. Tani, G. Erra, and D. Casadei, “A comparison of four robust control schemes for field-weakening operation of induction motors,” *IEEE Trans. Power Electron.*, vol. 27, no. 1, pp. 307–320, Jan. 2012.
- [3] S. Ziaeinejad, Y. Sangsefidi, H. P. Nabi, and A. Shoulaie, “Direct torque control of two-phase induction and synchronous motors,” *IEEE Trans. Power Electron.*, vol. 28, no. 8, pp. 4041–4050, Aug. 2013.
- [4] P. Sergeant, F. De Belie, and J. Melkebeek, “Rotor geometry design of interior PMSM with and without flux barriers for more accurate sensorless control,” *IEEE Trans. Ind. Electron.*, vol. 59, no. 6, pp. 2457–2465, Jun. 2012.
- [5] Accetta, M. Cirrincione, M. Pucci, and G. Vitale, “Sensorless control of PMSM fractional horsepower drives by signal injection and neural adaptive-band filtering,” *IEEE Trans. Ind. Electron.*, vol. 59, no. 3, pp. 1355–1366, Mar. 2012.
- [6] S. K. Sahoo, S. Dasgupta, S. K. Panda, and J. X. Xu, “A Lyapunov function-based robust direct torque controller for a switched reluctance motor drive system,” *IEEE Trans. Power Electron.*, vol. 27, no. 2, pp. 555–564, Feb. 2012.
- [7] K. Liu, Z. Q. Zhu, Q. Zhang, and J. Zhang, “Influence of nonideal voltage measurement on parameter estimation in permanent-magnet synchronous machines,” *IEEE Trans. Ind. Electron.*, vol. 59, no. 6, pp. 2438–2447, Jun. 2012.
- [8] J. Lee, J. Hong, K. Nam, R. Ortega, L. Praly, and A. Astolfi, “Sensorless control of surface-mount permanent-magnet synchronous motors based on a nonlinear observer,” *IEEE Trans. Power Electron.*, vol. 25, no. 2, pp. 290–297, Feb. 2010.
- [9] J. Sopenan, V. Ruuskanen, J. Nerg, and J. Pyrhonen, “Dynamic torque analysis of a wind turbine drive train including a direct-driven permanent magnet generator,” *IEEE Trans. Ind. Electron.*, vol. 58, no. 9, pp. 3859–3867, Sep. 2011.